

SWITCH 2008GT Quick Installation Guide

1. Overview

SWITCH 2008GT Unmanaged Industrial Ethernet Switch is specially designed to expand reliable Ethernet connectivity to factory floors and outdoor environments with extreme temperature and climatic conditions.

SWITCH 2008GT is equipped with 8 x 10/100/1000 RJ45 Ports enclosed in IP30 housing.

2. Package Checklist

- SWITCH 2008GT Switch x 1

Panel view

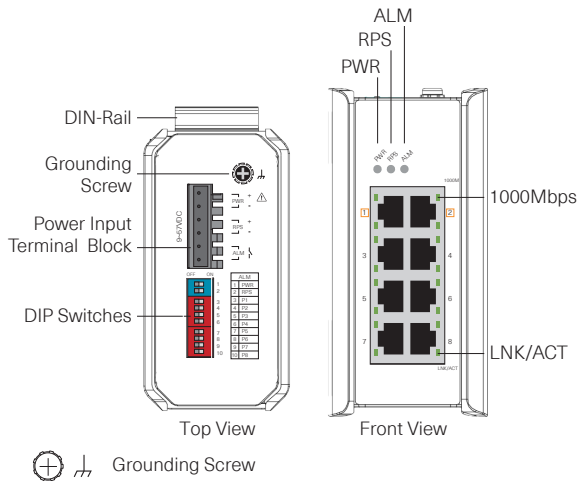

3. Mounting and Dismounting to DIN-Rail



ATTENTION:
The SWITCH 2008GT is an open type device and SWITCH 2008GT shall be DIN-Rail mounted in cabinet or enclosure and the ambient temperature should not exceed 75 °C.

Mounting the switch

Place the SWITCH 2008GT on the DIN rail from above using the slot, push the front of the switch toward the mounting surface until it snaps into place with a click sound.

Dismounting the switch

Press the switch from top and pull out the lower edge of the switch and then remove the switch from the DIN rail.

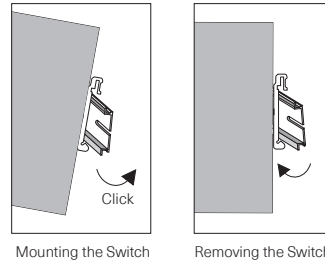

4. Grounding the switch SWITCH 2008GT

Grounding and wire routing help limit the effects of noise due to electromagnetic interference (EMI).

- Step 1: Run the ground connection from the ground screw to the grounding surface prior to connecting devices.
- Step 2: Connect the ground connection from the terminal block to the grounding surface prior to connecting device.



ATTENTION:
This product is intended to be mounted to a well-grounded mounting surface such as a metal panel.

5. Wiring requirements



WARNING:
Safety measures should be taken before connecting the power cable. Turn off the power before connecting modules or wires. The correct power supply voltage is listed on the product label. Check the voltage of your power source to make sure that you are using the correct voltage. DO NOT use a voltage greater than what is specified on the product label. Calculate the maximum possible current in each power wire and common wire. Observe all electrical codes dictating the maximum current allowable for each wire size. If current exceeds the maximum rating, the wiring can overheat causing serious damage to your equipment.

Please read and follow these guidelines:

- Use separate paths to route wiring for power and devices. If power wiring and device wiring paths must cross make sure the wires are perpendicular at the intersection point
NOTE: Do not run signal or communications wiring and power wiring through the same wire conduit. To avoid interference, wires with different signal characteristics should be routed separately
- You can use the type of signal transmitted through a wire to determine which wires should be kept separate. The rule of thumb is that wiring that shares similar electrical characteristics can be bundled together
- You should separate input wiring from output wiring
- We advise that you label the wiring to all devices in the system

5.1 Wiring Power Input

5.1.1 SWITCH 2008GT with 6pin terminal block

You can use "PWR" for Primary Power input and "RPS" for Redundant Power Input.

Top view of Terminal Block is shown in the figure below:

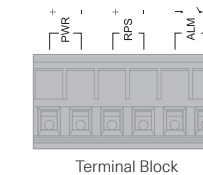

- Caution:**
- Use copper conductors only
 - Wiring cable temperature should support at least 105°C
 - Tighten the wire to a torque value 20N
 - The wire gauge for the terminal block should range between 0.2 to 2.5 mm²

To insert power wire and connect the 9 to 57 V DC at a maximum of 1 A DC power to the power terminal block, follow the steps below:

- Use flat-head screw driver to loosen the wire-clamp screws
- Insert the negative/positive DC wires into the PWR-/PWR+ terminals, respectively
- Tighten the wire-clamp screws to prevent the wires from loosening



ATTENTION:
Please use a power supply from 9 to 57 V DC, the device power shall be supplied by SELV circuit.

5.2 Wiring the relay contact (ALM)

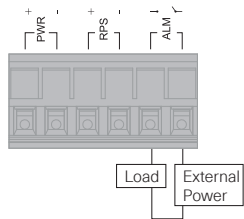

The SWITCH 2008GT has one set of relay alarm output. This relay contact uses two contacts of the terminal block on the top panel.

The two contacts of the 6-pin terminal block connector are used to detect user-configured events. The two wires attached to the fault contacts form an open circuit when a user-configured event is triggered. If a user-configured event does not occur, the fault circuit remains closed.

Relay rating: 24V, 1A

5.3 Cabling RJ45

Connect one end of an Ethernet/RJ45 cable into Ethernet port of SWITCH 2008GT and other end to attached networking device.

- Ports 1-8 of the switch support Fast Ethernet as well as Gigabit Ethernet (10/100/1000Base-T RJ45 Ports)
- All the RJ45 ports on the SWITCH 2008GT support auto negotiation and auto MDI/MDI-X to eliminate the need for crossover cabling

Note: Category 5e cable or above should be used.

6. DIP Switch Setting

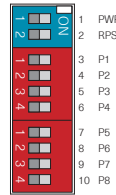

PWR	ON	Primary power alarm reporting is enabled
	OFF	Primary power alarm reporting is disabled
RPS	ON	Redundant power alarm reporting is enabled
	OFF	Redundant power alarm reporting is disabled
P1	ON	Port 1 link alarm reporting is enabled
	OFF	Port 1 link alarm reporting is disabled
P2	ON	Port 2 link alarm reporting is enabled
	OFF	Port 2 link alarm reporting is disabled
P3	ON	Port 3 link alarm reporting is enabled
	OFF	Port 3 link alarm reporting is disabled
P4	ON	Port 4 link alarm reporting is enabled
	OFF	Port 4 link alarm reporting is disabled
P5	ON	Port 5 link alarm reporting is enabled
	OFF	Port 5 link alarm reporting is disabled
P6	ON	Port 6 link alarm reporting is enabled
	OFF	Port 6 link alarm reporting is disabled
P7	ON	Port 7 link alarm reporting is enabled
	OFF	Port 7 link alarm reporting is disabled
P8	ON	Port 8 link alarm reporting is enabled
	OFF	Port 8 link alarm reporting is disabled



ATTENTION:
This device complies with Part 15 of the FCC rules. Operation is subject to the following conditions:
1. This device may not cause harmful interference
2. This device must accept any interference received including interference that may cause undesired operation



ATTENTION:
If the equipment is used in a manner not specified by SALZ Automation, the protection provided by the equipment may be impaired.

Address of the manufacturer:

SALZ Automation GmbH

Max-Planck-Str. 64

32107 Bad Salzufflen, Germany

Email: support@salz-automation.com

Please scan for more information:



7. LED Indicators

PWR (Green)	Illuminated	Power On by terminal block PWR or DC-Jack
	Off	Terminal block PWR/DC-Jack fails or is not available
RPS (Green)	Illuminated	Power On by terminal block RPS
	Off	Terminal block RPS fails or is not available
ALM (Red)	Illuminated	PWR/RPS fails or not available
	Off	No power lost or DIP function is disabled
1000M (Green)	Illuminated	Link speed at 1000Mbps
	Off	Link speed at 10/100Mbps
LNK/ACT (Green)	Illuminated	Copper port link-up 1000Mbps
	Blinking	Data is transmitting / receiving
	Off	Port disconnected or link failed

8. Environmental limits

Operating Temperature	-40°C ... 75°C
Storage Temperature	-40°C ... 80°C
Altitude	Up to 2000m
Ambient relative humidity	10 to 95% (non-condensing)
UL61010	Indoor use and pollution degree 2