

CONTROLLER AMAX 70 Pure

Quick Installation Guide

Order no. / SKU: SA-AMAX-5570-00

Address of the manufacturer:
SALZ Automation GmbH

Max-Planck-Str. 64
32107 Bad Salzufflen, Germany
Email: support@salz-automation.com



Overview

Intel® Atom® Control IPC, Linux based, with EtherCAT Slice I/O extension

Function
Ultra-compact Linux-based control platform with Intel® Atom® quad-core processor, 64GB eMMC onboard storage, 4 GB DDR4 onboard memory, 2 x LAN, 2 x USB, 2 x CAN, 2 x COM, and 1 x HDMI, EtherCAT IO expansion

1. Frontview

Front View of AMAX-70

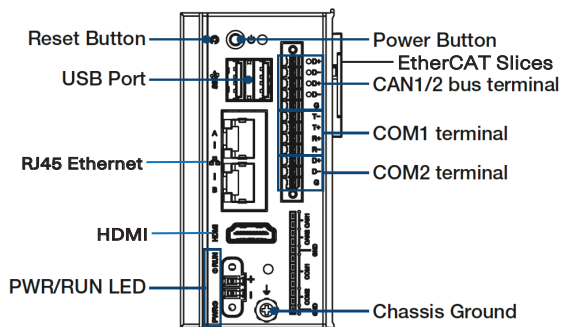

Legend of Configuration for the AMAX-70 CPU Module

No.	Component	Description
1	EtherCAT Slices	Connection for EtherCAT Slice IO extension modules.
2	USB Ports	Interfaces USB 3.2 for peripherals such as mouse.
3	RJ45 Ethernet	Connecting to local networks, internet or EtherCAT.
4	HDMI	Digital interface for a monitor with audio output.
5	CAN1/2	CAN bus terminals.
6/7	COM1/2	Serial com. RS-232/ 422/485 selectable in BIOS.
8	Chassis Ground	Screw to fix the shielding ground connection.
9	Reset Button	Hidden button for PC hardware reset function.
10	Power Button	Button for PC power function.
11	PWR/RUN LEDs	Diagnostic LEDs for CPU module.
12	Power Terminal	2-pin terminal for 24 V DC power.

2. COM connector

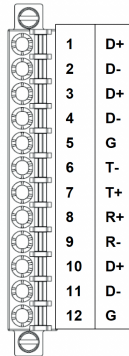

CAN bus/COM port Connector Pin Assignments			
Pin	CAN Pin define	PIN mark	Signal Name
1	CAN1	D+	CAN H
2		D-	CAN L
3	CAN2	D+	CAN H
4		D-	CAN L
5	CAN GND	G	GND
Pin	COM1 Mode	PIN mark	Signal Name
6	RS232	T-	CTS
	RS422		T-
	RS485		D-
7	RS232	T+	RXD
	RS422		T+
	RS485		D+
8	RS232	R+	TXD
	RS422		R+
9	RS232	R-	RTS
	RS422		R-
Pin	COM2 Mode	PIN Mark	Signal Name
10	RS485	D+	D+
11		D-	D-
12	GND	G	GND

3. Wiring Power Input

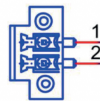

CONTROLLER AMAX 70 comes with a screw connector that carries 24 V DC external power input, and features reversed wiring protection. Therefore, the system will not cause damage from reversed polarity of ground lines and power lines.

4. Environmental limits

Operating Temperature	-20 ... 60 °C @ 5 ... 85% RH with 0.7 m/s airflow (without expansion)
	-20 ... 55 °C @ 5 ... 85% RH with 0.7 m/s airflow (with mPCIe + EtherCAT expansion)
Storage Temperature	-40 ... 85 °C (-40 ... 185 °F)
Ambient relative humidity	10 ... 95% @ 40 °C (non condensing)

5. Software Details and Configuration

Overview

This quick installation guide will explain the operation of the software SALZ Automation System Software "PURE". 'PURE' is the primary software for the AMAX 80-C and AMAX 70 controllers from SALZ Automation. The PURE version comes pre-installed in the controllers and is easy to understand and work with. It can be accessed by using the specific IP in the internet browser on the PC. The GUI is user friendly, containing info-graphic components for optimal usage.

With 'PURE' the automation system is made independent of internet at least when it comes to installing the required applications. Automation software/applications can be installed by using a USB flash drive or using locally stored files on your PC. This quick installation guide will walk you through the processes and methods of using the software efficiently and conveniently.

For information not addressed in this document visit www.salz-automation.com or contact us at hello@salz-automation.com.

1. Accessing the Software

Once turned on, the controller can be accessed by ethernet ports. Connect the PC to the controller to one of the two ethernet ports. Port 1: DHCP / Port 2: Static IP- address **192.168.221.10**
Open the internet browser to access the dashboard using the IP.

Default Credentials:

Username	admin
Password	changeme

2. User Options

User options can be found after clicking  on the top right corner of the browser. You can 'Change User Password' and 'Manage User' in this window. 'User History' can also be accessed.

3. Dashboard

The Dashboard contains, CPU, Memory, and Disk usage. It also has a realtime graphical representation of the same. App summary shows you the installed applications and their status. System Information gives you the details of the firmware and the ability to manage/change it.

4. System Settings

KEY ELEMENTS:

- **Time Settings-** This screen is where you set up the date, time, and time zone for your SALZ Automation device. If you want your device to always show the correct time, simply select your location (Europe/Berlin), check the option to use an external time server if you want automatic updates, or set the date and time manually before clicking "Apply" to save your changes.
- **Firmware Management-** SALZ controllers have two memory partitions where two different versions of firmware can be installed. Switching between the firmware is easy and can be done with only one click.
 - A firmware update is uploaded on the active memory partition.
 - The existing firmware version moves to the inactive memory partition once the new firmware is uploaded.

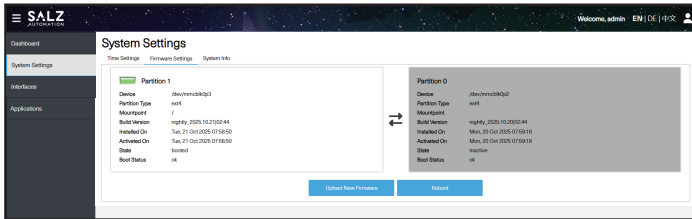

- **System Info-** This is where you can see the operating system information and its build version.

5. Interfaces

This section contains 'Network Connection Settings' where the configuration of Backplane, Port 1, and Port 2 of the controller can be edited.

6. Applications

This section contains an overview of the installed applications on the controller.

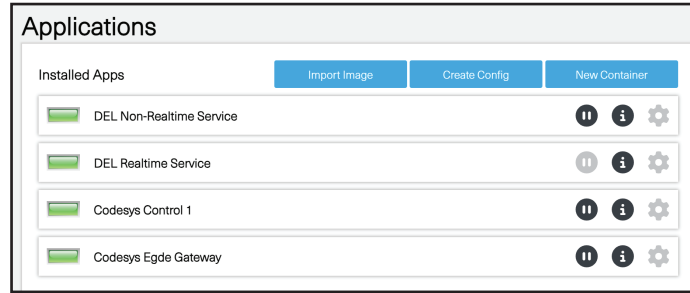

- II This button lets you stop the application.
- i This button gives you information of the individual apps.
- gear This button lets is to edit the settings of the application.

-4-

6.1 Import Image Button

This option allows you to import the images of the applications (.tar files) on the container from your local device, USB etc. The source of the images can be the SALZ Automation website or the dockerhub desktop application as well.

For more information on this visit: [Learn about SALZ Software Center](#)

6.2 Create Config Button

This option lets you create configuration file (.json) for the image of your choice.

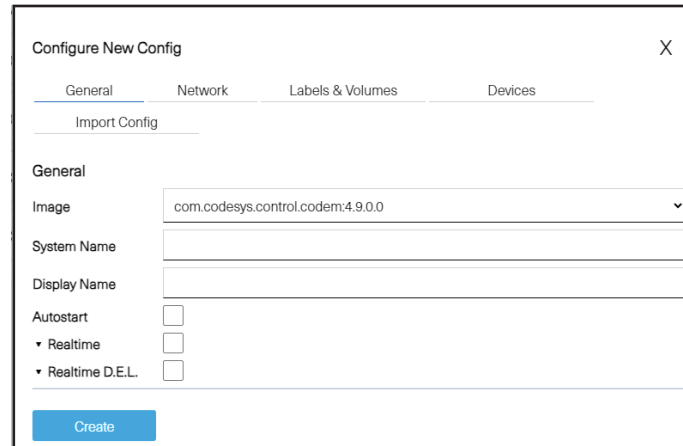

-5-

6.2.1- General: Select image, give it system and display name.

6.2.2- Network: Set the 'Ports' and 'Network' infrastructure.

6.2.3- Labels & Volumes:

6.2.4- Devices:

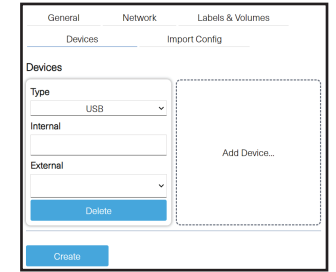
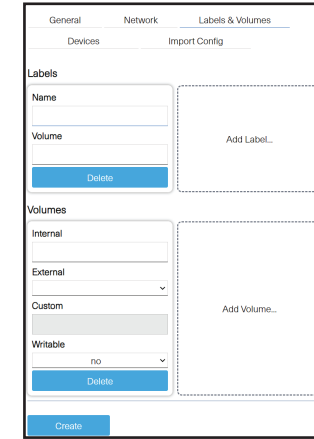

6.2.5- Import Config:

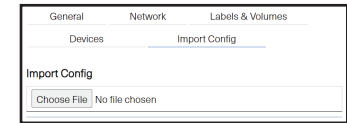

Steps 6.2.3 lets you set labels and volumes, 6.2.4 lets you set the device configurations, and with 6.2.5 you can easily import the configuration files customised by you.

6.3 New Container Button

This option allows you to create containers from the imported images. Multiple instances/containers can be created from one single image imported in the controller.

- 1: Select the image for which you want to create a container.
- 2: Create or import the configurations as shown in 6.2.
- 3: Click 'Create'.

Visit www.salzautomation.com for more information.

-6-